



ÖZKAN

MAKİNA VE İNŞAAT SAN. TİC. LTD. ŞTİ

www.ozkanmak.com.tr



ÖZKAN MAKİNA,

40 yılı aşkın bilgi birikimiyle özellikle otomotiv sanayi ve çeşitli sanayilere müşterinin belirlediği teknik şartnamelere tam uygunluk ilkesiyle hareket ederek, ağırlıklı olarak döküm, dövme, her türlü çelik ve alüminyum parçaların hassas ve seri üretimini gerçekleştirmekteyiz. Müşterilerimize yüksek kaliteli ve güvenilir parçalar sunmayı hedeflemekteyiz.

SUNDUĞUMUZ AVANTAJLAR

- İşleme olan yüksek adetli parçaların, hassas ve seri olarak üretimi
- Döküm ve dövme parçaların talaşlı imalatı konusunda uzman olmamız
- Son teknolojiye sahip makine parkı
- Tüm aparatların SolidWorks ile tasarımı
- 3 Boyutlu koordinat ölçme ve parçaya özel ölçme cihazları ile kalite kontrolü
- boya, kaplama, ısıl işlem, kaynak gibi diğer üretim yöntemleri ile çalışan firmalar ile entegre çalışarak montaj dahil son ürünü sunma kabiliyeti



- Türkiye’de yaygın döküm ve dövme hatları, yerli çelik ve metal ürünleri sayesinde kolay ham madde temini
- yapıcı ve çözüme yönelik çalışma tarzı
- DIN EN ISO 9001 : 2015 sertifikası
- ISO/TS 16949 ile ilgili çalışmalarımız sürmektedir



MAKİNE PARKİMİZ

- 3 CNC TORNA ; X 350MM, Z 530MM
- 6 CNC DIK TORNA ; X 550MM, Z 625MM
- 3 CNC DIK TORNA ÇİFT ÇAKI :X550MM,Z625MM
- 1 ÇİFT PALET YATAY İŞLEME MERKEZİ
X 560MM, Y 510MM, Z 630MM
- 1 ÇİFT PALET YATAY İŞLEME MERKEZİ
X 650MM, Y 650MM, Z 650MM
- 1 ÇİFT PALET YATAY İŞLEME MERKEZİ
X 800MM, Y 800MM, Z 800MM
- 1 ÇİFT PALET YATAY İŞLEME MERKEZİ
X 850MM, Y 700MM, Z 750MM
- 1 ÇİFT PALET DIKEY İŞLEME MERKEZİ
X 800MM, Y 600MM, Z 600MM
- ÇİFT PALET DIKEY İŞLEME MERKEZİ
X 600MM, Y 450MM, Z 700MM
- 1 ÇİFT PALET DIKEY İŞLEME MERKEZİ
X 800MM, Y 500MM, Z 500MM
- 1 DIVİZÖRLÜ DIKEY İŞLEME MERKEZİ
X 1000MM, Y 500MM, Z 510MM
 - 2 OTOMATİK BALANS TEZGAHI
 - 1 YARI OTOMATİK BALANS TEZGAHI
- 1 BROŞ / BIÇAK GENİŞLİĞİ : 3-25 MM, Ø14-115 MM
- 3 BOYUTLU KOORDİNAT ÖLÇME CİHAZI
 - HEXAGON – COORD 3





www.ozkanmak.com.tr

ÇALIŞMA ALANIMIZ

KAPALI ALAN 2000m²

AÇIK ALAN 500m²







ÖLÇÜM CİHAZLARI

- 2 Adet 3 Boyutlu koordinat ölçme cihazı (HEXAGON -COORD3) □
- Özel ölçüm sistemleri
- Yüzey pürüzlülüğü ölçüm cihazı (Mitutoyo)
- Havalı mastar- Özel mastarlar
- Mikrometre
- Dijital mihengir
- Kumpas vb.



ÖZKAN MAKİNA,
üretim süreçlerinde kullanılan tüm
aparathların tasarımını, kendi bünyesinde
SolidWorks programı ile gerçekleştirir.
Üretim, bilgisayar ortamında gerekli
testler yapıldıktan ve son kalite kontrol
süreci tamamlandıktan sonra başlatılır.

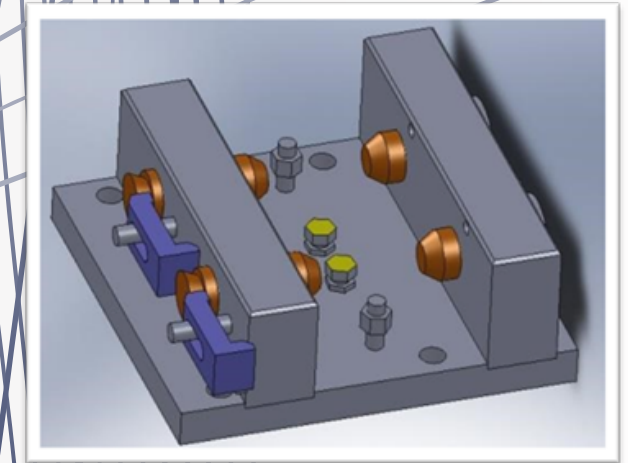
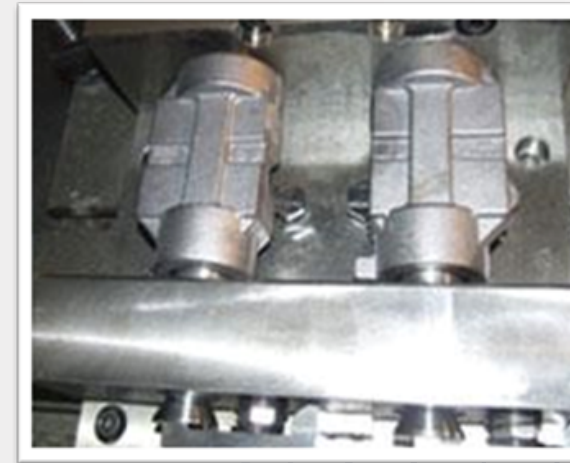
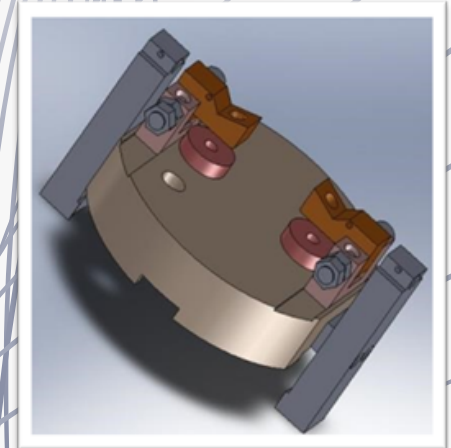
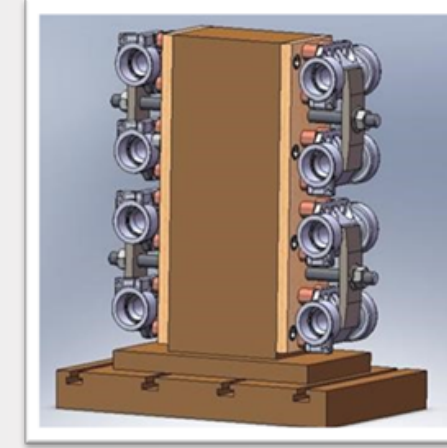







Referanslarımız;

FERRO DÖKÜM Sanayi ve Dış Ticaret A.Ş.	DEMİSAŞ Döküm Emaye Mamulleri Sanayi A.Ş.	KANCA El Aletleri Döv. Çel. ve Mak. San. A.Ş	DÖKTAŞ DÖKÜMCÜLÜK TİC. SAN. AŞ
ÇEMAŞ Döküm Sanayi A.Ş.	LARIOTECHNIK	RENAULT	FORD
VOLVO	VIBRACOUSTIC	HALDEX	TRAKYA DÖKÜM SAN. TİC. AŞ

 **ÖZKAN**

ÖZKAN MAKİNA VE İNŞAAT SAN. TİC. LTD. ŞTİ.

Esenehir Mahallesi, Güneylı Sokak No: 19
34776 Ümraniye / İstanbul / Türkiye

Tel: +90 216 313 50 20-21 Fax: +90 216 313 50 22

E-mail: ozkanmak@ozkanmak.com.tr

Web: www.ozkanmak.com.tr

LANTA® | **BRAKE DISC
PRODUCTION**