



ÖZKAN

MAKİNA VE İNŞAAT SAN. TİC. LTD. ŞTİ

www.ozkanmak.com.tr



www.ozkanmak.com.tr

ÖZKAN MAKİNA,

Özkan Makina, with its knowledge of more than 40 years, acts with the principle of full compliance with the technical specifications determined by the customer, especially for the automotive industry and various industries, and carries out precision and mass production of all kinds of steel and aluminum parts, mainly casting, forging. We aim to provide high quality and reliable parts to our customers

THE ADVANTAGES WE OFFER

- Precision and high-volume production of parts for machining.
- Expertise in the machining of cast and forged parts.
- State-of-the-art machinery.
- Design of all fixtures using SolidWorks.
- Quality control with 3D coordinate measuring and custom measuring devices.
- Ability to provide the final product including assembly, through integration with companies using other production methods such as painting, coating, heat treatment, and welding.



- **Widespread casting and forging lines in Turkey, enabling easy access to domestic steel and metal products.**
- **Constructive and solution-oriented working style.**
- **DIN EN ISO 9001:2015 certification.**
- **Ongoing efforts related to ISO/TS 16949.**



MACHINE PARK

3D COORDINATE MEASURING MACHINE

- HEXAGON – COORD 3
- 3x CNC TURNING CENTER ;
X 350mm , Z 530mm
- 6x CNC TURNING CENTER ;
X 550mm , Z 6250mm
- 3x CNC VERTICAL TURNING CENTER WITH DOUBLE TOOL KNIFE
X 550mm , Z 625mm
- 1x DOUBLE PALLET HORIZONTAL MACHINING CENTER
X 560mm , Y 510mm , Z 630mm
- 1x DOUBLE PALLET HORIZONTAL MACHINING CENTER
X 650mm , Y 650mm , Z 650mm
- 1x DOUBLE PALLET HORIZONTAL MACHINING CENTER
X 800mm , Y 800mm , Z 800mm
- 1x DOUBLE PALLET HORIZONTAL MACHINING CENTER
X 850mm , Y 700mm , Z 750mm

- 1x DOUBLE PALLET VERTICAL MACHINING CENTER
X 800mm , Y 600mm , Z 600mm
- 1x DOUBLE PALLET VERTICAL MACHINING CENTER
X 600mm , Y 450mm , Z 700mm
- 1x DOUBLE PALLET VERTICAL MACHINING CENTER
X 800mm , Y 500mm , Z 500mm
- 1x DIVIDING HEAD VERTICAL MACHINING CENTER
X 1000mm , Y 500mm , Z 510mm
- 2 AUTOMATIC BALANCING MACHINE
- 1 SEMIAUTOMATIC BALANCING MACHINE • Blade width: 3-
25mm - Ø14-115mm





www.ozkanmak.com.tr

PRODUCTION AREA

TOTAL AREA 2500m²

COVERED AREA 2000m²



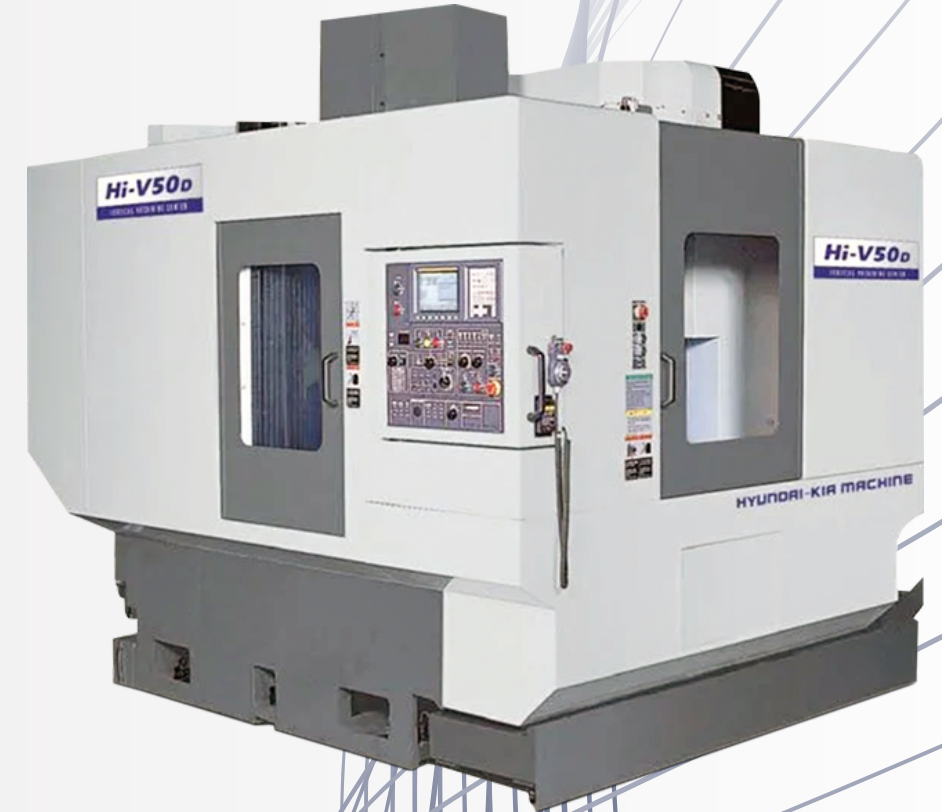



MEASURING DEVICES

- **2 Units of 3D coordinate measuring machines (HEXAGON-COORD3)**
- **Custom measurement systems**
- **Surface roughness measurement device (Mitutoyo)**
- **Pneumatic gage**
- **Micrometer**
- **Digital caliper**
- **Calipers, etc.**



ÖZKAN MAKİNA, designs fixturing systems with Solid Works. After having applied software-supported tests and having performed final quality checks, the fixturing systems are manufactured in house.

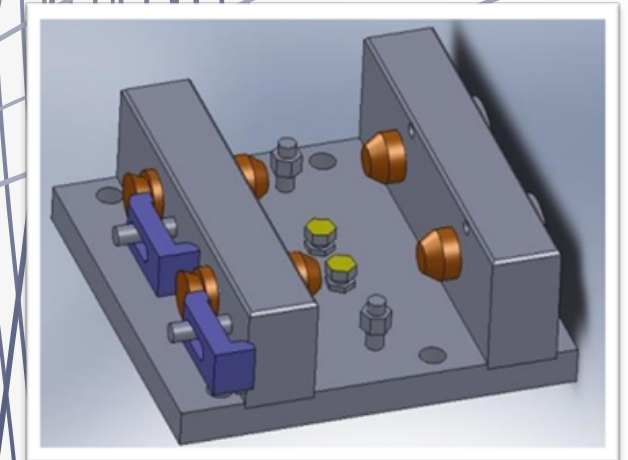
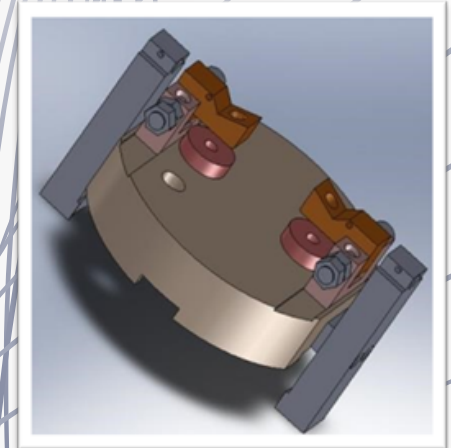
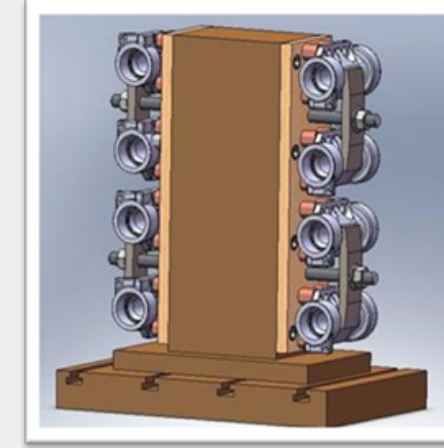







References

<p>FERRO DÖKÜM Sanayi ve Dış Ticaret A.Ş.</p>	<p>DEMİSAŞ Döküm Emaye Mamulleri Sanayi A.Ş.</p>	<p>KANCA El Aletleri Döv. Çel. ve Mak. San. A.Ş</p>	<p>DÖKTAŞ DÖKÜMCÜLÜK TİC. SAN. AŞ</p>
<p>ÇEMAŞ Döküm Sanayi A.Ş.</p>	<p>LARIOTECHNIK</p>	<p>RENAULT</p>	<p>FORD</p>
<p>VOLVO</p>	<p>VIBRACOUSTIC</p>	<p>HALDEX</p>	<p>TRAKYA DÖKÜM SAN. TİC. AŞ</p>

 ÖZKAN

ÖZKAN MAKİNA VE İNŞAAT SAN. TİC. LTD. ŞTİ.

Esenehir Mahallesi, Güneyli Sokak No: 19
34776 Ümraniye / İstanbul / Türkiye

Tel: +90 216 313 50 20-21 Fax: +90 216 313 50 22

E-mail: ozkanmak@ozkanmak.com.tr

Web: www.ozkanmak.com.tr

 LANTA® | BRAKE DISC
PRODUCTION